

Combilift



handling materials - in all directions

C8000 Electric

making short work of long loads



Forward / Reverse Mode



Carousel Mode



Sideward Mode



Customized Handling Solutions



www.combilift.com

three machines in one

"counterbalance forklift; sideloader; aisle truck"

Specifications Model C8000 Electric

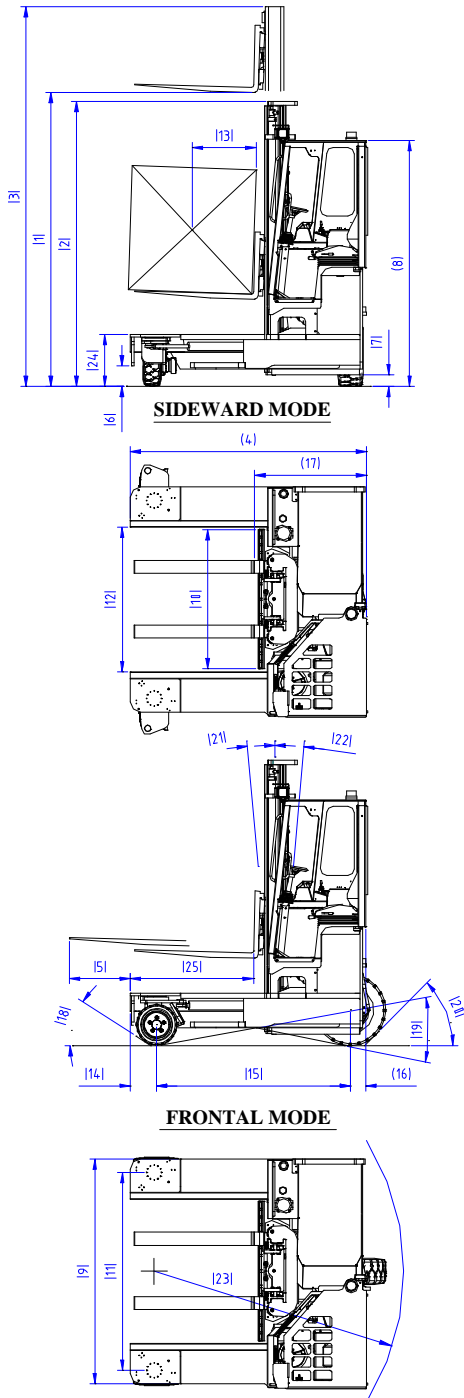

Ref.	Description	STANDARD MAST
1 a	Max. Lift Height	159"
1 b	Free Lift Height	0"
2	Height Mast Closed	112 1/2"
3	Max. (Mast raised)	193 3/4"
4	Overall Length	93 1/2"
5	Mast Travel	49 1/4"
6	Ground Clearance Under Mast	6"
7	Ground Clearance to Center of Wheelbase	5"
8	Height Over Cab or of Overhead Guard	96"
9	Width	86"
10	Outside Spread of Fork Arms	53"
11	Track Front	78"
12	Frame Opening	55"
13	Load Center Distance	24"
14	Overhang Front	9 1/2"
15	Wheel Base	75 1/2"
16	Overhang Back	8 1/2"
17	Length From Face of Fork	46 1/4"
18	Approach Angle	45°
19	Ramp Angle	17°
20	Departure Angle	45°
21	Forward Tilt	3°
22	Backward Tilt	5°
23	Minimum Outside Radius	94"
24	Platform Height	19 1/2"
25	Platform Length	47 1/4"
A	Capacity	8000lbs
B	Unladen Weight	14900lbs
C	Maximum Ground Speed	7 mph
D	Gradability	10%
E	Battery Capacity (V / Ah)	80V / 625Ah
F	Fork Section	1 3/4" x 6" x 47 1/4"
G	16 x 7 - 10.5 Front Tire (Solid)	OD 16"/ Width 7"
H	27 x 10 - 12 Rear Tire (Super Elastic)	OD 27"/ Width 10"
I	Standard Color	Green and Grey

Features Include:

- ? Rubber Mounted Half Open Cabin
- ? Multi-Direction Operation
- ? Load Sensing Steering
- ? 2 Wheel Hydrostatic Drive
- ? 4-Way Lever Positioning of Wheels
- ? Hydraulic Oil Cooler
- ? AC Motor Technology



The C8000E has a single rear wheel providing excellent manoeuvrability.



The operator compartment on the C8000 Electric



The battery compartment on the C8000 Electric



The hydraulic pump connected to the electric motor powers the drive wheels and the hydraulic functions

Distributor

**Combilift USA, 303 Concord Street,
Greensboro NC27406, USA**
Tel. 877 COMBI 56 **Fax. 336 378 8842**
www.combilift.com **info@combilift.com**

Combilift has a policy of continuous product development and reserves the right to alter specifications without prior notice. Specifications and / or dimensions may vary from those illustrated in some countries.