



COMBiLiFT

THE Solution to your Poultry Collection Problems



BENEFITS:

- Small Turning Radius
- Operates Indoor And Outdoor
- Reduced Maintenance Costs
- No Mechanical Brakes To Adjust Or Replace
- Visibility-Offset Driving Position Gives Excellent View for Poultry Cage positioning



FEATURES:

- 3 Wheel Maneuverability
- All Wheel Hydrostatic Drive
- 30° Fork Rotation - Each Way
- 3 Stage Mast With Full - Free Lift
- Large Tractor Grip Tires
- Diff-Lock Feature
- Deep Suspension Seat
- Back Up Alarm
- 6" Mast Side Shift
- Pivot Forks

**COMBi - RT
Poultry**

www.COMBiLiFT.com



SPECIFICATIONS

COMBi - RT

DESCRIPTION	STD
Capacity	3,000lbs @ 48" L.C.
Unladen Weight	9,400lbs
Max. Ground Speed	9 mph
Gradeability	40%
Kubota Water Cooled Diesel Engine	60 Hp
Electrics	12 Volt
Pivot Fork Section	2" x 5" x 72"
Slew Bearing Fork Rotator	30° Each Way
Pneumatic Tractor Grip Tires	ø 36" width 11 1/2"
Diesel Tank Capacity	25 Gallons
3 Wheel Hydrostatic Drive	
3 Wheel Hydrostatic Braking	
Conforms to ANSI B56.6 Safety Standard for Rough Terrain Forklift Trucks	

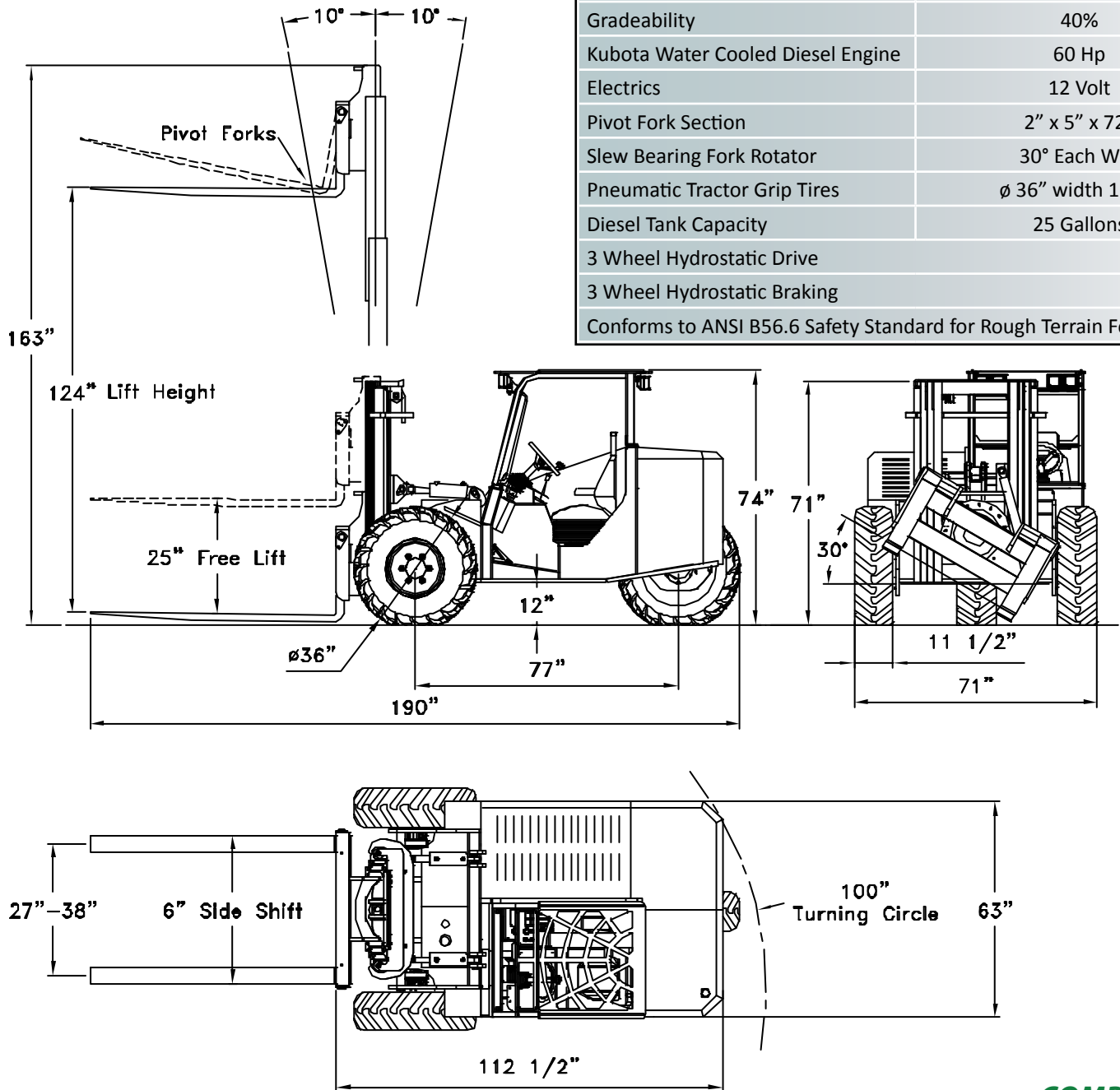

Distributed by



COMBiLiFT USA

303 Concord Street, Greensboro,
North Carolina 27406

Toll Free: 1 - 877 COMBI 56

Tel: 336 - 378 - 8884 Fax: 336 - 378 - 8842

E: info@combilift.com

COMBiLiFT HQ

Gallinagh, Co Monaghan, IRELAND

Tel: +353 47 80500 Fax: +353 47 80501

www.COMBiLiFT.com

Combilift has a policy of continuous product development and reserves the right to alter specifications without prior notice. Specifications and/or dimensions may vary from those illustrated in some countries.