

# Features

## Original Linde hydrostatic drive

- Responsive, smooth and precise driving
- No clutch, differential or drum brakes; hydrostatic drive assumes function of service brake
- Robust drive system, proven in severe duty environments
- Low maintenance costs and long life



## Linde ProtectorFrame

- Safe and robust chassis, enclosed on all sides
- Engine hood and servicing doors open wide for convenient access to all components

## Linde dual travel control

- Quick change of forward/reverse direction
- Short pedal stroke
- No leg fatigue
- Increased productivity

## Linde Load Control (LLC)

- Accurate, safe load handling
- Effortless fingertip control of all hydraulic functions
- Traction and all hydraulic functions completely separate

## High-economy engine technology

- Diesel and LPG engines incorporating the most advanced technology
- High torque
- Low fuel consumption
- Low exhaust gas and soot emission levels
- 9.7 gal. capacity fuel tank (diesel)



## Operator compartment

- Designed to advanced ergonomic standards
- Spacious cab with automobile equivalent legroom
- Excellent visibility of load and surroundings
- Cushioned drive and steer axles reduce road shock
- Standard sound abatement design (75/73 dBa)

## Linde Truck Control (LTC)

- Reliable microprocessor controller technology
- Easily matched to individual application requirements
- Component protection resulting from redundant monitoring systems
- Automatic control of engine RPM

## Linde clear-view mast

- Superb visibility
- Exceptional residual capacity
- Zero-maintenance shock mounting of mast and tilt cylinders
- Electronic limiting of tilt angle

Linde Material Handling North America Corporation  
 2450 West 5th North Street, Summerville, SC 29483  
 Phone: (843) 875.8000 • Truck Sales Fax: (843) 875.8471  
 E-mail: trucksales@lmh-na.com • Web Site: www.lmh-na.com

Linde Material Handling



ANSI: Standard truck meets all applicable mandatory requirements of ANSI/ISO 856.1 standards for powered industrial trucks.  
 NOTE: Performance data may vary due to motor and system efficiency tolerances. The performance depicted represents nominal values unless otherwise specified.  
 All metric dimensions are not direct equivalents due to rounding data. The descriptions and specifications included on this data sheet were in effect at the time of printing. Linde Material Handling North America Corporation reserves the right to make improvements and changes in specification or design without incurring obligation. Please check with your authorized Linde dealer for information on possible updates or revisions.

linde\_spec\_391 D/1  
 USA\_V3-060311\_P00



Diesel and LPG Forklift Trucks  
 Capacity 3000, 3500, and 4000 lb  
 H16D/T, H18D/T, and H20D/T  
 SERIES 391

Linde Material Handling



## Safety

Linde ProtectorFrame: The overhead guard and its supporting frame form a strong and completely enclosed protective zone providing optimum structural integrity and safety. The top mounted tilt cylinders provide seamless, smooth control of the tilt movements for excellent load stability in all operating conditions.

## Performance

Low fuel consumption levels, low exhaust emissions, and impressive performance. Advanced engine and drive technology combined with the original Linde Load Control system enable the operator to use the truck's potential to maximise productivity. Comfortable and precise fingertip control of all hydraulic functions.

## Comfort

Climb on board relaxed, finish the shift relaxed. Designed to the most advanced ergonomic standards. Spacious cab interior, adjustable armrest, suspension seat, and functional positioning of easy-actuation controls make for a stress-free working environment.

## Reliability

Proven in tough sustained operations. Isolation of the cab from the mast, drive axle and chassis results in reduced shock and vibrations. Maintenance-free and elastic mounting of axles and tilt cylinders cuts downtime and operating costs.

## Productivity

Effective and cost efficient: The "New Generation" Linde hydrostatic drive eliminates torque converter transmission, clutch, differential, and drum brakes. As a result, servicing costs are low, truck uptime is high and productivity is enhanced.

# Standard and optional equipment

## Standard equipment:

Linde twin drive pedals to control forward/reverse travel and braking

Linde Load Control integrated in armrest

Hydraulic-suspension comfort-class seat with extensive range of adjustments

Hydrostatic steering with on-demand power assist

Dual engine combustion air pre-cleaners

High-performance hydraulic filters

Comprehensive overhead digital instrumentation display (anti-glare surface )

Plenty of storage space

Top-mounted tilt cylinders

Zero-maintenance mast and tilt cylinder mountings

Twin front work lamps

Regulated catalytic muffler (LP)

Parking brake

Tow pin

Anti restart ignition

LPG ultrasonic fuel level indicator (LP only)

## Options:

Single drive pedal with direction selector positioned on armrest

Integral sideshift

Auxiliary hydraulic circuits for all mast types

Overhead guard can be upgraded to full cabin with roof, front and rear screens and doors (also available with tinted glass)

Wiper-washers for front, rear and roof screens

Cab heater with integral pollen filter

Roof shade, clipboard, interior lighting

LBR

Truck lighting, work lamps

Audible reversing alarm, amber warning light

Paperwork clip board

17° Pivoting operators seat

Electronic tilt angle limiting

Custom paint

Catalytic muffler (diesel)

Mirrors

Other options available on request

# Downrating Charts\*

Reference SE tires with standard carriage and forks only

## H16D/T (188 Triple Mast)

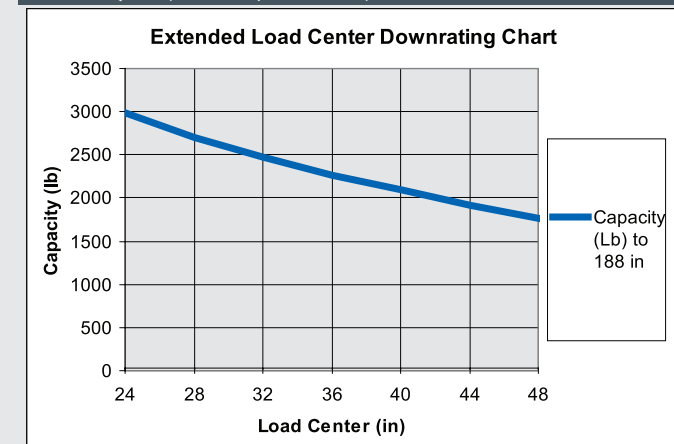

## H18D/T (188 Triple Mast)

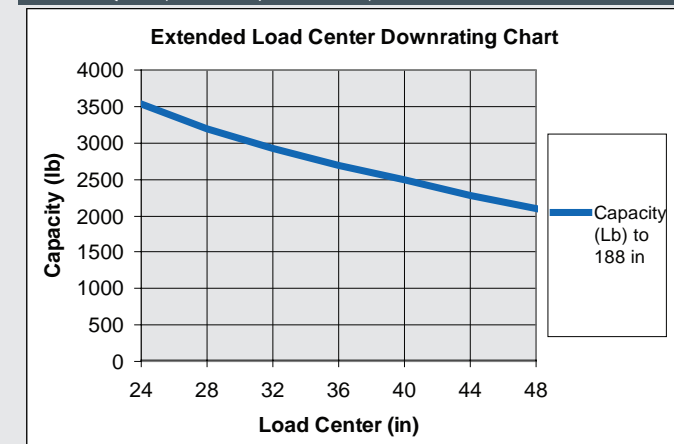

## H20D/T (188 Triple Mast)

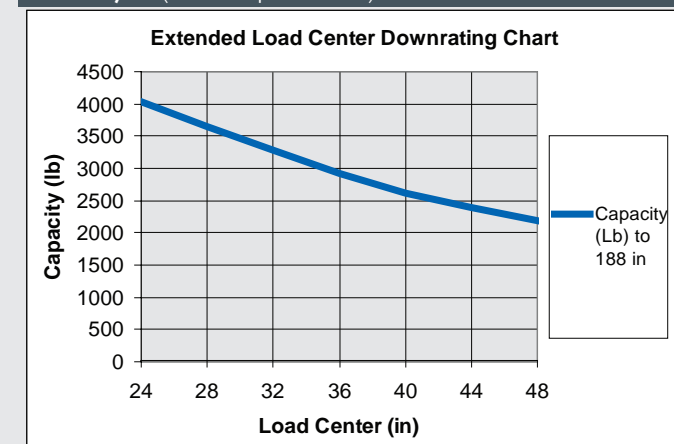

\*For quick reference only, contact factory for detailed ratings.

\*\*Capacity ratings can be affected by changing forks, load center, and/or drive tires.



# Capacity and Mast Information\*

## 391-01 Series (H16D/T)

1.5" x 4" x 42" Forks\*\*  
SE 180/70-8 (18 X 7-8) SC 15 Drive Tires\*\*

Mast Capacity Table

h1	h3	h2	
83.5	124	0.0	Simple
91.5	138.5	0.0	Simple
83.5	123	60	Dual
91.5	139	68	Dual
83.5	182	60	Triple
85.5	188	62	Triple
91.5	206	68	Triple
97.5	215	70.5	Triple

Capacity (lb) @ 24" Load Center\*\*

Std. Carriage*	Integral SS Carriage*	Hang-on SS Carriage*
3,000	3,000	2,865
3,000	3,000	2,865
3,000	3,000	2,865
3,000	3,000	2,865
3,000	2,850	2,820
2,985	2,685	2,685
2,650	2,175	2,175
2,385	1,895	1,895

## 391-01 Series (H18D/T)

1.5" x 4" x 42" Forks\*\*  
SE 200/50-10 SC 15 Drive Tires\*\*

Mast Capacity Table

h1	h3	h2	
83.5	124	0.0	Simple
91.5	138.5	0.0	Simple
83.5	123	60	Dual
91.5	139	68	Dual
83.5	182	60	Triple
85.5	188	62	Triple
91.5	206	68	Triple
97.5	215	70.5	Triple

Capacity (lb) @ 24" Load Center\*\*

Std. Carriage*	Integral SS Carriage*	Hang-on SS Carriage*
3,500	3,500	3,280
3,500	3,500	3,280
3,500	3,500	3,280
3,500	3,500	3,280
3,500	3,375	3,280
3,500	3,190	3,190
3,245	2,630	2,630
2,925	2,320	2,320

## 391-01 Series (H20D/T)

1.5" x 4" x 42" Forks\*\*  
SE 200/50-10 SC 15 Drive Tires\*\*

Mast Capacity Table

h1	h3	h2	
83.5	124	0.0	Simple
91.5	138.5	0.0	Simple
83.5	123	60	Dual
91.5	139	68	Dual
83.5	182	60	Triple
85.5	188	62	Triple
91.5	206	68	Triple
97.5	215	70.5	Triple

Capacity (lb) @ 24" Load Center\*\*

Std. Carriage*	Integral SS Carriage*	Hang-on SS Carriage*
4,000	4,000	3,670
4,000	4,000	3,670
4,000	4,000	3,670
4,000	4,000	3,670
4,000	3,775	3,670
4,000	3,570	3,570
3,635	2,955	2,955
3,275	2,590	2,590

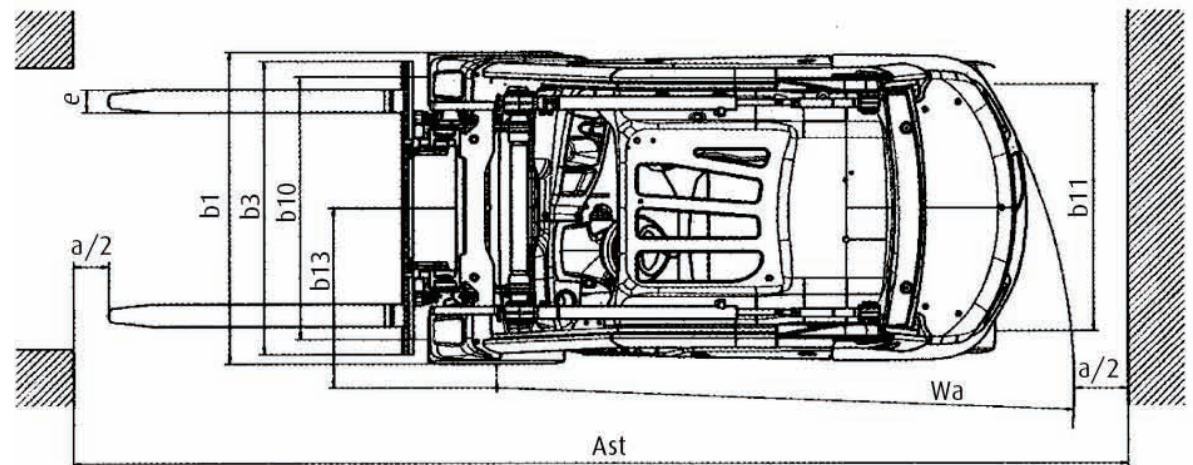
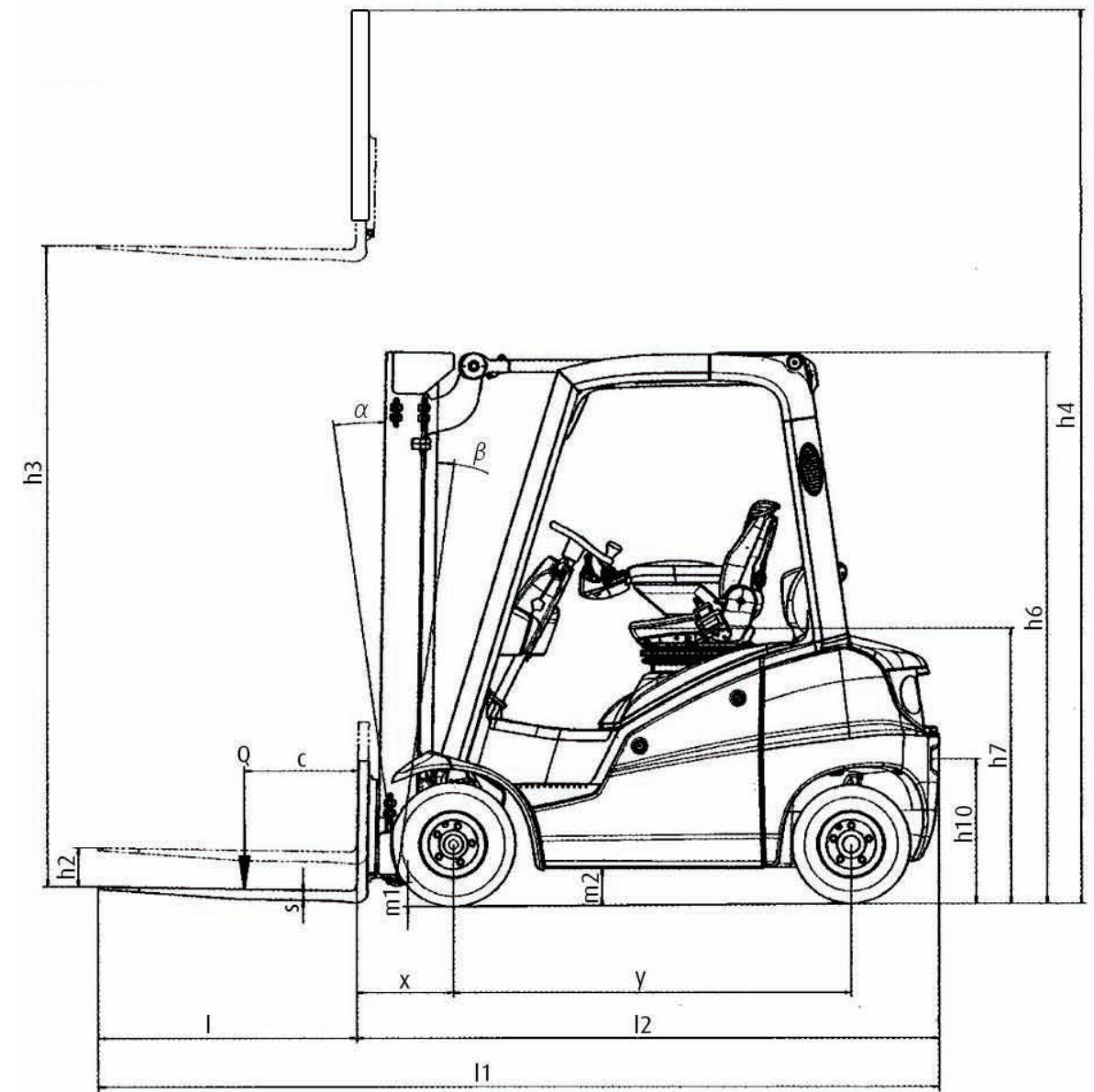

# Technical data

October 2010

SERIES 391 D/T

		Linde		Linde		Linde				
		H16D	H16T	H18D	H18T	H20D	H20T			
Characteristics	1.1	Manufacturer	Linde		Linde		Linde		1.1	
	1.2	Model designation	H16D	H16T	H18D	H18T	H20D	H20T	1.2	
	1.3	Power unit: battery, diesel, gasoline, LP gas, AC	Diesel	LP	Diesel	LP	Diesel	LP	1.3	
	1.4	Operation: manual, pedestrian, rider standing, rider seated, order picker	Rider seated		Rider seated		Rider seated		1.4	
	1.5	Load capacity	Q lb (kg)	3000 (1600)	3000 (1600)	3500 (1800)	3500 (1800)	4000 (2000)	4000 (2000)	1.5
	1.6	Load center	c in (mm)	24 (500)	24 (500)	24 (500)	24 (500)	24 (500)	24 (500)	1.6
	1.8	Load distance (center of drive axle to fork face)	x in (mm)	14.3 (365)	14.3 (365)	14.3 (370)	14.3 (370)	14.5 (374)	14.5 (374)	1.8
	1.9	Wheelbase	in (mm)	59.1 (1500)	59.1 (1500)	60.6 (1540)	60.6 (1540)	63.0 (1600)	63.0 (1600)	1.9
	Weight	2.1	Service weight	lb (kg)	6052 (2745)	6008 (2725)	6415 (2910)	6371 (2890)	6746 (3060)	6702 (3040)
2.2		Axle loading with load, front/rear	lb (kg)	7805/1247 (3820/525)	7717/1291 (3780/545)	8671/1244 (4160/550)	8583/1288 (4120/570)	9500/1246 (4480/580)	9412/1290 (4440/600)	2.2
2.3		Axle loading without load, front/rear	lb (kg)	2855/3197 (1295/1450)	2767/3241 (1255/1470)	2954/3461 (1340/1570)	2866/3505 (1300/1590)	3064/3682 (1390/1670)	2976/3726 (1350/1690)	2.3
Wheels & Tires	3.1	Tire type - front/rear: C (cushion), SE (cushion super elastic), P (pneumatic)	SE		SE		SE		3.1	
	3.2	Tire size: front	in (mm)	18 x 7-8	200 / 50-10		200 / 50-10		3.2	
	3.3	Tire size: rear	in (mm)	18 x 7-8	18 x 7-8		18 x 7-8		3.3	
	3.5	Wheels: number front/rear (x = driven)		2 x / 2	2 x / 2		2 x / 2		3.5	
	3.6	Track width, front	b10 in (mm)	36.6 (930)	36.6 (930)	36.6 (930)	36.6 (930)	37.2 (945)	37.2 (945)	3.6
	3.7	Track width, rear	b11 in (mm)	34.4 (873)	34.4 (873)	34.4 (873)	34.4 (873)	34.4 (873)	34.4 (873)	3.7
	Dimensions	4.1	Mast/fork carriage tilt: forward/back	degrees	6.0/6.0	6.0/6.0	6.0/6.0	6.0/6.0	6.0/6.0	6.0/6.0
4.2		Height of mast lowered	h1 in (mm)	See mast table		See mast table		See mast table		4.2
4.3		Free lift	h2 in (mm)	See mast table		See mast table		See mast table		4.3
4.4		Lift	h3 in (mm)	See mast table		See mast table		See mast table		4.4
4.5		Height of mast extended	h4 in (mm)	h3 + 48"		h3 + 48"		h3 + 48"		4.5
4.7		Height of overhead guard/cab	h6 in (mm)	83.6 (2123)	83.6 (2123)	83.6 (2123)	83.6 (2123)	83.6 (2123)	83.6 (2123)	4.7
4.8		Height of seat	h7 in (mm)	42.0 (1067)	42.0 (1067)	42.0 (1067)	42.0 (1067)	42.0 (1067)	42.0 (1067)	4.8
4.12		Height of tow coupling	h10 in (mm)	21.9 (557)	21.9 (557)	21.6 (549)	21.6 (549)	20.9 (530)	20.9 (530)	4.12
4.19		Overall length	l1 in (mm)	129.0 (3112)	129.0 (3112)	130.4 (3152)	130.4 (3152)	133.5 (3231)	133.5 (3231)	4.19
4.20		Length to fork face	l2 in (mm)	87.0 <sup>1</sup> (2212) <sup>1</sup>	87.0 <sup>1</sup> (2212) <sup>1</sup>	88.4 <sup>1</sup> (2252) <sup>1</sup>	88.4 <sup>1</sup> (2252) <sup>1</sup>	91.5 <sup>1</sup> (2331) <sup>1</sup>	91.5 <sup>1</sup> (2331) <sup>1</sup>	4.20
4.21		Overall width	b1/b2 in (mm)	42.8 <sup>3</sup> (1086) <sup>3</sup>	42.8 <sup>3</sup> (1086) <sup>3</sup>	42.8 <sup>3</sup> (1086) <sup>3</sup>	42.8 <sup>3</sup> (1086) <sup>3</sup>	45.4 (1152)	45.4 (1152)	4.21
4.22		Fork dimensions	s/e/l in	1.5x4x42	1.5x4x42	1.5x4x42	1.5x4x42	1.5x4x42	1.5x4x42	4.22
4.23		Fork carriage: class		2A	2A	2A	2A	2A	2A	4.23
4.24		Width of fork carriage	b3 in (mm)	40.9 (1040)	40.9 (1040)	40.9 (1040)	40.9 (1040)	40.9 (1040)	40.9 (1040)	4.24
4.31		Ground clearance under mast, with load	m1 in (mm)	3.7 (93)	3.7 (93)	3.6 (92)	3.6 (92)	3.7 (95)	3.7 (95)	4.31
4.32		Ground clearance, center of wheelbase	m2 in (mm)	4.7 (119)	4.7 (119)	4.6 (118)	4.6 (118)	4.8 (121)	4.8 (121)	4.32
4.33	Aisle width	Ast in (mm)	93.3 <sup>2</sup> (2370) <sup>2</sup>	93.3 <sup>2</sup> (2370) <sup>2</sup>	94.9 <sup>2</sup> (2411) <sup>2</sup>	94.9 <sup>2</sup> (2411) <sup>2</sup>	98.2 <sup>2</sup> (2495) <sup>2</sup>	98.2 <sup>2</sup> (2495) <sup>2</sup>	4.33	
4.35	Turning radius	Wa in (mm)	78.9 (2005)	78.9 (2005)	80.4 (2041)	80.4 (2041)	83.5 (2121)	83.5 (2121)	4.35	
4.36	Minimum pivot point distance	b13 in (mm)	23.6 (600)	23.6 (600)	24.2 (615)	24.2 (615)	25.1 (638)	25.1 (638)	4.36	
Performance	5.1	Travel speed, with/without load	mph (km/h)	12.4/12.4 (20.0/20.0)	12.4/12.4 (20.0/20.0)	12.4/12.4 (20.0/20.0)	12.4/12.4 (20.0/20.0)	12.4/12.4 (20.0/20.0)	12.4/12.4 (20.0/20.0)	5.1
	5.2	Lifting speed, with/without load	fpm (m/s)	118.1/124.0 (0.6/0.63)	118.1/124.0 (0.6/0.63)	118.1/124.0 (0.6/0.63)	118.1/124.0 (0.6/0.63)	106.3/112.2 (0.54/0.57)	106.3/112.2 (0.54/0.57)	5.2
	5.3	Lowering speed, with/without load	fpm (m/s)	112.2/112.2 (0.57/0.57)	112.2/112.2 (0.57/0.57)	112.2/112.2 (0.57/0.57)	112.2/112.2 (0.57/0.57)	112.2/112.2 (0.57/0.57)	112.2/112.2 (0.57/0.57)	5.3
	5.5	Drawbar pull, with/without load	lbs (N)	2900/2282 (12900/10150)	2900/2214 (12900/9850)	2900/2360 (12900/10500)	2900/2293 (12900/10200)	2900/2450 (12900/10900)	2900/2383 (12900/10600)	5.5
	5.7	Climbing ability, with/without load	%	32 / 38	32 / 37	29 / 37	29 / 36	27 / 36	27 / 36	5.7
	5.9	Acceleration, with/without load	sec	4.9/4.3	4.9/4.3	5.0/4.5	5.0/4.5	5.1/4.6	5.1/4.6	5.9
	5.10	Service brake		Hydrostatic		Hydrostatic		Hydrostatic		5.10
Engine	7.1	Engine manufacturer/model		VW / BXT	VW / BEF	VW / BXT	VW / BEF	VW / BXT	VW / BEF	7.1
	7.2	Engine rating	hp (kW)	34.9 (26)	37.5 (28)	34.9 (26)	37.5 (28)	34.9 (26)	37.5 (28)	7.2
	7.3	Rated speed	rpm <sup>1</sup>	2100	2100	2100	2100	2100	2100	7.3
	7.4	Number of cylinders/Engine displacement	cu in (cc)	4/116 (4/1896)	4/121 (4/1984)	4/116 (4/1896)	4/121 (4/1984)	4/116 (4/1896)	4/121 (4/1984)	7.4
Other	8.1	Traction control		Hydraulic/ininitely variable		Hydraulic/ininitely variable		Hydraulic/ininitely variable		8.1
	8.2	Working pressure for attachments	psi (bar)	2466 (170)	2466 (170)	2466 (170)	2466 (170)	2466 (170)	2466 (170)	8.2
	8.3	Oil flow attachments	gal/min (l/min)	10.0 (38)	10.0 (38)	10.0 (38)	10.0 (38)	10.0 (38)	10.0 (38)	8.3
	8.4	Noise level at driver's ear	dB(A)	75	73	75	73	75	73	8.4

<sup>1</sup> Add 1 in (25 mm) for triple mast

<sup>2</sup> Plus length of load plus clearance for 90° stack

<sup>3</sup> SE tires 200/50-10 for simple and dual mast from 177 in. lift and triple mast from 185 in. lift add 3.2 in (81 mm)